

LamaPLC: Eastron SDM 630 Energy Meter with Modbus communication

The Eastron SDM630 is a series of three-phase, multifunctional DIN-rail-mounted energy meters used to measure and monitor electrical parameters in industrial, commercial, and residential applications. It is known for its high accuracy, compact design, and communication interfaces.



Key Features

- **Multifunctional Measurement:** The meter measures a wide range of parameters, including active energy (kWh), reactive energy (kVARh), active power (W), apparent power (VA), voltage (V), current (A), power factor (PF), frequency (Hz), and total harmonic distortion (THD) for all phases.
- **Direct Connection:** Most models support direct connection for loads up to 100 A, eliminating the need for external current transformers (CTs) for many applications. Other variants, such as the SDM630MCT, are designed to operate with external CTs for higher-current applications.
- **Communication:** It features built-in interfaces, including RS485 Modbus RTU and dual pulse outputs, for remote monitoring and integration into Building Management Systems (BMS), energy management systems, or solar inverters (e.g., Deye, Growatt).
- **Display and Usability:** The meter has a clear, backlit LCD and user-friendly, password-protected menu navigation via touch-sensitive buttons on the front panel.
- **Certification:** Many models, such as the SDM630-Modbus-MID V2, are MID-certified, making them suitable for legally compliant billing.
- **Versatility:** It is compatible with single-phase two-wire, three-phase three-wire, and three-phase four-wire network configurations.

Technical Specifications

According to Eastron Europe datasheets and user manuals, the specifications for the standard SDM630 models are as follows:

Parameter	Specification
Nominal Voltage (Un)	3×230/400 V AC
Maximum Current (Imax)	100 A (direct measurement)
Accuracy Class	Class 1 (IEC 62053-21) / Class B (EN50470-3)
Frequency Range	50 or 60 Hz
Communication	RS485 Modbus RTU, two pulsed outputs
Display	Backlit LCD
Mounting	35mm DIN rail
Protection Degree	IP51 (indoor use)
Operating Temperature	-25°C to +55°C

Eastron SDM630 Version V1, V2, and V3

The primary difference among the Eastron SDM630 V1, V2, and V3 versions lies in the firmware and specific energy calculation methods, particularly how the meters handle imported and exported energy.

Key Differences Summary

- **V1 (Legacy):** The initial version with basic functionality and limited register addresses. It is supported only by certain software configurations at baud rates of 9600 or higher.
- **V2 (Standard/Net-Counting):** Introduced “net-counting” calculation, meaning the total energy measurement combines (Import minus Export) values. It added features such as a second resettable total energy counter and had slightly different default Modbus settings and options in its menus.
- **V3 (Enhanced Functionality/MID):** The latest version is often certified for commercial billing (MID certification). Functionally, it is very similar to V2 but ensures compliance with newer standards, includes updated firmware (typically post-2022 build dates), and may have slightly different default configurations in some supplier-specific models.

Detailed Comparison Points

Feature	SDM630 V1	SDM630 V2	SDM630 V3
Energy Calculation	Basic Import/Export	Net-counting (Total = Import - Export)	Net-counting, often with separate registers
Resettable Energy	Limited options	Includes second resettable total energy counter	Same as V2, possibly enhanced options
Firmware Date	Older builds	Typically prior to 2022	Typically 2022 or later
Modbus Registers	Limited set	More extensive, with added registers	Largely consistent with V2 core registers
Certifications	Standard	Standard, and MID options	Standard and MID options, focus on recent compliance

Modbus Protocol Consistency

Crucially, the core Modbus register addresses for real-time measurements (*voltage, current, power, frequency*) are largely identical across all versions. The main differences users encounter typically relate to the interpretation of the total energy registers and minor menu/configuration variations.

The default Modbus communication settings (Address 1, 9600 baud, 8N1) are generally consistent across all three versions, though supplier customizations exist.

Modbus communication

Read Limits: Do not attempt to read more than 40 parameters (80 registers) in a single Modbus request to avoid exception errors.

RS485 communication interface, MODBUS RTU protocol:

- Baudrate: 9600 Baud (default, can be set)
- Parity: Even

- Databits: 8
- Stopbits: 1
- Default slave ID: 1 (SMD72D), 45 (SDM72CTM)
- Number of Drivers and Receivers: 32 Drivers, 32 Receivers (without repeater)
- Maximum Cable Length: 1200 m
- Maximum Data Rate: 10 Mbaud
- Maximum Common Mode Voltage: 12 V .. -7 V
- Minimum Driver Output Levels (Loaded): +/- 1.5 V
- Minimum Driver Output Levels (Unloaded): +/- 6 V
- Drive Load: Minimum 60 ohms
- Driver Output Short Circuit Current Limit: 150 mA to Gnd, 250 mA to 12 V, 250 mA to -7 V
- Minimum Receiver Input Resistance: 12 kΩ
- Receiver Sensitivity: +/- 200 mV

Convert word array to real array

The Input registers are in a word format and must be converted into real numbers in pairs. This conversion involves straightforward bit-level merging, which can be implemented in LabView, for example, as shown below:

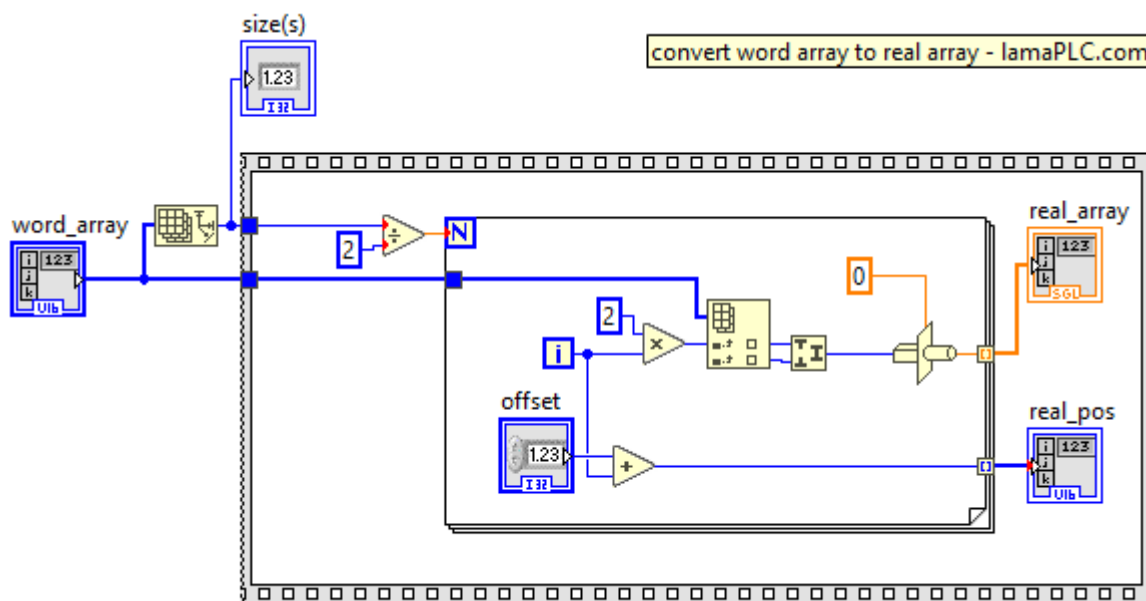

32-bit (2 words) input registers

The registers are read-only. All values are 4-byte IEEE 754 float type.

Register Nr	32 bit address	Description	Unit	Type SDM...
30001	1	Phase 1 Line to Neutral Volts	V	72, 230, 630
30003	2	Phase 2 Line to Neutral Volts	V	72, 630
30005	3	Phase 3 Line to Neutral Volts	V	72, 630
30007	4	Phase 1 Current	A	72, 230, 630

Register Nr	32 bit address	Description	Unit	Type SDM...
30009	5	Phase 2 Current	A	72, 630
30011	6	Phase 3 Current	A	72, 630
30013	7	Active Power Phase 1	W	72, 230, 630
30015	8	Active Power Phase 2	W	72, 630
30017	9	Active Power Phase 3	W	72, 630
30019	10	Apparent Power Phase 1	VA	72, 230, 630
30021	11	Apparent Power Phase 2	VA	72, 630
30023	12	Apparent Power Phase 3	VA	72, 630
30025	13	Reactive Power Phase 1	VAr	72, 230, 630
30027	14	Reactive Power Phase 2	VAr	72, 630
30029	15	Reactive Power Phase 3	VAr	72, 630
30031	16	Power Factor Phase 1 (pos: forward Current, neg: reverse Current)	-	72, 230, 630
30033	17	Power Factor Phase 2 (pos: forward Current, neg: reverse Current)	-	72, 630
30035	18	Power Factor Phase 3 (pos: forward Current, neg: reverse Current)	-	72, 630
30037	19	Phase 1 Phase angle	Degrees	230, 630
30039	20	Phase 2 Phase angle	Degrees	630
30041	21	Phase 3 Phase angle	Degrees	630
30043	22	Average Line to Neutral Volts	V	72, 630
30047	24	Average Line Current	A	72, 630
30049	25	Summary of Line Currents	A	72, 630
30053	27	Total System Power	W	72, 630
30057	29	Total System Apparent Power	VA	72, 630
30061	31	Total System Reactive Power	VAr	72, 630
30063	32	Total System Power factor (pos: forward Current, neg: reverse Current)	-	72, 630
30067	34	Total System Phase angle	Degrees	630
30071	36	Frequency of Supply Voltages	Hz	72, 230, 630
30073	37	Total Import Energy	kWh	72, 230, 630
30075	38	Total Export Energy	kWh	72, 230, 630
30077	39	Total Import Reactive Energy	kVArh	230, 630
30079	40	Total Export Reactive Energy	kVArh	230, 630
30081	41	Total Power	kVAh	630
30083	42	Current Hour	Ah	630
30085	43	Total System Power Demand (Power sum Demand calculation is for Import - Export)	W	230, 630
30087	44	Maximum total System Power Demand (Power sum Demand calculation is for Import - Export)	VA	230, 630
30089	45	Current System positive Power Demand	W	230, 630
30091	46	Maximum System positive Power Demand	W	230, 630
30093	47	Current System reverse Power Demand	W	230, 630
30095	48	Maximum System reverse Power Demand	W	230, 630

Register Nr	32 bit address	Description	Unit	Type SDM...
30101	51	Total System Apparent Power Demand	VA	630
30103	52	Maximum Total System Apparent Power Demand	VA	630
30105	53	Neutral Current Demand	A	630
30107	54	Maximum Neutral Current Demand	A	630
30201	101	Line 1 to Line 2 Volts	V	72, 630
30203	102	Line 2 to Line 3 Volts	V	72, 630
30205	103	Line 3 to Line 1 Volts	V	72, 630
30207	104	Average Line to Line Volts	V	72, 630
30225	113	Neutral Current	A	72, 630
30235	118	Phase 1 L/N Volts THD	%	630
30237	119	Phase 2 L/N Volts THD	%	630
30239	120	Phase 3 L/N Volts THD	%	630
30241	121	Phase 1 Current THD	%	630
30243	122	Phase 2 Current THD	%	630
30245	123	Phase 3 Current THD	%	630
30249	125	Average Line to Neutral Volts THD	%	630
30251	126	Average Line Current THD	%	630
30259	130	Phase 1 Current Demand	A	230, 630
30261	131	Phase 2 Current Demand	A	630
30263	132	Phase 3 Current Demand	A	630
30265	133	Maximum Phase 1 Current Demand	A	230, 630
30267	134	Maximum Phase 2 Current Demand	A	630
30269	135	Maximum Phase 3 Current Demand	A	630
30335	168	Line 1 to Line 2 Volts THD	%	630
30337	169	Line 2 to Line 3 Volts THD	%	630
30339	170	Line 3 to Line 1 Volts THD	%	630
30341	171	Average Line to Line Volts THD	%	630
30343	172	Total Active Energy (total kWh / kVarh equals Import + Export)	kWh	72, 230, 630
30345	173	Total Reactive Energy (total kWh / kVarh equals Import + Export)	kvarh	72, 230, 630
30347	174	L1 Import Active Energy	kWh	630
30349	175	L2 Import Active Energy	kWh	630
30351	176	L3 Import Active Energy	kWh	630
30353	177	L1 Export Active Energy	kWh	630
30355	178	L2 Export Active Energy	kWh	630
30357	179	L3 Export Active Energy	kWh	630
30359	180	L1 total Active Energy (total kWh / kVarh equals Import + Export)	kWh	630
30361	181	L2 total Active Energy (total kWh / kVarh equals Import + Export)	kWh	630
30363	182	L3 total Active Energy (total kWh / kVarh equals Import + Export)	kWh	630
30365	183	L1 Import Reactive Energy	kvarh	630
30367	184	L2 Import Reactive Energy	kvarh	630

Register Nr	32 bit address	Description	Unit	Type SDM...
30369	185	L3 Import Reactive Energy	kvarh	630
30371	186	L1 Export Reactive Energy	kvarh	630
30373	187	L2 Export Reactive Energy	kvarh	630
30375	188	L3 Export Reactive Energy	kvarh	630
30377	189	L1 total Reactive Energy (total kWh / kVarh equals Import + Export)	kvarh	630
30379	190	L2 total Reactive Energy (total kWh / kVarh equals Import + Export)	kvarh	630
30381	191	L3 total Reactive Energy (total kWh / kVarh equals Import + Export)	kvarh	630
30385	193	Current Resettable Total Active Energy	kWh	72, 230, 630
30387	194	Current Resettable Total Reactive Energy	kvarh	72, 230, 630
30389	389	Resettable Import Active Energy	kWh	72
30391	391	Resettable Export Active Energy	kWh	72
30397	397	Netto Energy (Import - Export)	kWh	72
31281	1281	Total Import Active Power	W	72
31283	1283	Total Export Active Power	W	72

The additional energy meters with Easton-type Modbus communication: [SDM72](#), [SDM230](#), [SDM630](#)

Source:

https://www.eastroneurope.com/images/uploads/products/protocol/SDM630_MODBUS_Protocol.pdf

SDM630/SDM230 Modbus Import registers in .csv file-format



If you'd like to support the development of the site with the price of a coffee — or a few — [please do so here](#).

Here's a handy tip: you can quickly save this page as a PDF by clicking "export to PDF" in the menu on the right side of the screen.

2026/02/14 23:38

32-bit (2 words) holding registers

Registers are classified as read-only (**r**), read/write (**rw**), or write-only (**w**). All values are 4-byte IEEE 754 floating-point numbers.

Register Nr	32 bit address	Parameter	Valid range	type	Type SDM...
40003	3	Demand period	Specify demand periods as 0, 5, 8, 10, 15, 20, 30, or 60 minutes, with 60 as the default. Setting the period to 0 displays the current parameter value for demand, while demand max shows the highest parameter value since the last reset.	Length: 4 byte Data Format: Float Mode:rw	630
40011	11	System type	Write system type: 3p4w = 3, 3p3w = 2, and 1p2w= 1. Requires password, see parameter "password".	Length: 4 byte Data Format: Float Mode:rw	72, 630
40013	13	Pulse 1 width	Specify pulse1 duration in milliseconds: 60, 100, or 200, with 100 as the default.	Length: 4 byte Data Format: Float Mode:rw	230, 630
40015	15	Password lock	Enter any value to access password lock-protected registers. To check the lock status: 0 indicates locked, 1 indicates unlocked. Reading this status will also reset the password timeout to one minute.	Length: 4 byte Data Format: Float Mode:rw	630
40019	19	Network Parity Stop	Specify the network port parity and stop bits for the MODBUS Protocol as follows: 0 = One stop bit, no parity (default). 1 = One stop bit, even parity. 2 = One stop bit, odd parity. 3 = Two stop bits, no parity. A restart is required for changes to take effect.	Length: 4 byte Data Format: Float Mode:rw	72, 230, 630
40021	21	Network Node	Write the network port node address: 1 to 247 for MODBUS Protocol, default 1. Requires a restart to become effective.	Length: 4 byte Data Format: Float Mode:rw	72, 230
40023	23	Pulse1 Divisor1	Write pulse divisor index: n = 0 to 5 0: 0.0025 kWh(kVArh)/imp 1: 0.01 kWh(kVArh)/imp 2: 0.1 kWh(kVArh)/imp 3: 1 kWh(kVArh)/imp 4: 10 kWh(kVArh)/imp 5: 100 kWh(kVArh)/imp	Length: 4 byte Data Format: Float Mode:rw	630
40025	25	Password	Enter the password to access protected registers. Default: 0000.	Length: 4 byte Data Format: Float Mode:rw	630

Register Nr	32 bit address	Parameter	Valid range	type	Type SDM...
40029	29	Network Baud Rate	Write the network port baud rate for MODBUS Protocol, where: 0: 2400 baud 1: 4800 baud 2: 9600 baud, default 3: 19200 baud 4: 38400 baud Requires a restart to become effective	Length: 4 byte Data Format: Float Mode:rw	72, 230, 630
40063	63	Current Transformer ratio	Configurable scale from 1 to 2000, example: 200A:5A → 200 divided by 5 → Set value: 40	Length: 4 byte Data Format: Float Mode:rw	630
40087	87	Pulse 1 Energy Type	Write MODBUS Protocol input parameter for pulse output 1: 1: import active energy 2: total active energy 4: export active energy, default 5: import reactive energy 6: total reactive energy 8: export reactive energy	Length: 4 byte Data Format: Float Mode:rw	630
461457	-	reset	00 00 □reset the Maximum demand	Length: 2 byte Data Format: Hex Mode:w	630
462721	-	Demand Interval	Slide Time, Automatic Scroll Display Interval (Scroll Time), Backlight Time Scroll Time=0: the display does not scroll automatically Backlight Time=0: Backlight is Always On.	Length: 4 byte Data Format: BCD "min-min-s-min" Mode:rw	230
463761	-	System Power	Default Format: Hex 0000: 0.001kWh (kVArh) /imp (default) 0001: 0.01kWh (kVArh) /imp 0002: 0.1kWh (kVArh) /imp 0003: 1kWh (kVArh) /imp	Length: 4 byte Data Format: Float Mode:rw	230
463776	-	Measurement Mode	Data Format: Hex 0001: Mode 1 (Total = Import) 0002: Mode 2 (Total = Import + Export) 0003: Mode 3 (Total = Import - Export)	Length: 4 byte Data Format: Float Mode:rw	230

Register Nr	32 bit address	Parameter	Valid range	type	Type SDM...
463792	-	Pulse Output & LED Indicator Mode	Data Format: Hex 0000: Import & Export Energy, LED flashes for Import & Export Energy 0001: Import Energy, LED flashes for Import Energy only 0002: Export Energy, LED flashes for Export Energy only	Length: 4 byte Data Format: Float Mode:rw	230
464513	-	Serial number	Serial number	Length: 4 byte Data Format: unsigned int32 Mode:r	630

2026/06/05 15:50

Arduino & Eastron SDM 630

The Eastron SDM630 communicates via Modbus RTU over an RS-485 interface, requiring an RS-485 converter module and a dedicated library to read data on an Arduino. The **SDM_Energy_Meter library** simplifies this process.

Hardware Required

- **Arduino Board:** Any compatible board (Uno, Nano, Mega, ESP32).
- **RS485 to TTL Converter:** A module using chips like [MAX485](#), MAX3485, or SN75176 to convert RS485 signals to Arduino's 5V/3.3V logic levels. These typically have Data Enable (DE) and Receive Enable (RE) pins that need to be controlled by the Arduino.
- **Eastron SDM630:** Configured with default settings: Modbus address 1, baud rate 9600, 8 data bits, no parity, 1 stop bit (8N1).

Wiring Schematic ([MAX485 Module](#))

- MAX485 VCC → Arduino 5V
- MAX485 GND → Arduino GND
- MAX485 DI (Driver Input) → Arduino Pin 4 (TX for SoftwareSerial)
- MAX485 RO (Receiver Output) → Arduino Pin 3 (RX for SoftwareSerial)
- MAX485 DE (Driver Enable) → Arduino Pin 2 (Control pin)
- MAX485 RE (Receiver Enable) → Arduino Pin 2 (Connect DE and RE together as you only need one-way communication at a time)
- MAX485 A (RS485+ / Data+) → SDM630 A terminal
- MAX485 B (RS485- / Data-) → SDM630 B terminal

Arduino Example Code

This example uses the **SDM_Energy_Meter** library by reaper7 and the standard **SoftwareSerial** library.

```
#include <SoftwareSerial.h>
#include <SDM.h>
```

```
// Pins for the SoftwareSerial communication
// RX pin: 3, TX pin: 4
SoftwareSerial sdmSerial(3, 4);

// Pin 2 is used to control the DE/RE pins of the MAX485 converter
#define RS485_EN 2

// Create an SDM object (SoftwareSerial instance, Enable Pin)
SDM sdm(&sdmSerial, RS485_EN);

void setup() {
  Serial.begin(115200); // Serial monitor output
  sdmSerial.begin(9600); // SDM630 default baud rate

  Serial.println("\nEastron SDM630 Reader");
}

void loop() {
  // Read Voltage (Register 0x0000)
  float voltage = sdm.readVal(SDM_PHASE_1_VOLTAGE);
  if (!isnan(voltage)) {
    Serial.print("Voltage L1: ");
    Serial.print(voltage);
    Serial.println(" V");
  } else {
    Serial.println("Failed to read Voltage");
  }

  // Read Total System Power (Register 0x0034 or 0x0052 depending on
  // V1/V2/V3 meter version)
  // Check documentation for the specific register address
  float power = sdm.readVal(SDM_TOTAL_SYSTEM_POWER);
  if (!isnan(power)) {
    Serial.print("Total Power: ");
    Serial.print(power);
    Serial.println(" W");
  } else {
    Serial.println("Failed to read Power");
  }

  // Read Total Import Energy (Register 0x0048 or 0x0072 depending on
  // version)
  float energy = sdm.readVal(SDM_TOTAL_IMPORT_ENERGY);
  if (!isnan(energy)) {
    Serial.print("Import Energy: ");
    Serial.print(energy);
    Serial.println(" kWh");
  } else {
    Serial.println("Failed to read Energy");
  }
}
```

```
delay(3000); // Wait 3 seconds before next read  
}
```

[modbus](#), [modbus rtu](#), [eastron](#), [modbus map](#), [MID](#), [SDM](#), [SDM 630](#), [Arduino](#), [code](#)

This page has been accessed for: Today: 1, Until now: 80

From:

<https://lamaplc.de/> - **lamaPLC**

Permanent link:

https://lamaplc.de/doku.php?id=meas:eastron_sdm_630

Last update: **2026/06/05 15:55**

