

# IamaPlc: Industrial Ethernet (IE) Basic

Industrial Ethernet (IE) is the use of Ethernet in an industrial environment with protocols that provide determinism and real-time control. Protocols for industrial Ethernet include EtherCAT, EtherNet/IP, PROFINET, POWERLINK, SERCOS III, CC-Link IE, and Modbus TCP. Many industrial Ethernet protocols use a modified media access control (MAC) layer to provide low latency and determinism. Some microprocessors provide industrial Ethernet support.

Industrial Ethernet can also refer to the use of standard Ethernet protocols with rugged connectors and extended temperature switches in an industrial environment, for automation or process control. Components used in plant process areas must be designed to work in harsh environments of temperature extremes, humidity, and vibration that exceed the ranges for information technology equipment intended for installation in controlled environments. The use of fiber-optic Ethernet variants reduces the problems of electrical noise and provides electrical isolation.

Some industrial networks emphasized deterministic delivery of transmitted data, whereas Ethernet used collision detection which made transport time for individual data packets difficult to estimate with increasing network traffic. Typically, industrial uses of Ethernet employ full-duplex standards and other methods so that collisions do not unacceptably influence transmission times.

## Power over Ethernet

Power over Ethernet (PoE) refers to the ability to transfer both data and power within an individual Ethernet cable. Standards have been established by the IEEE, specifically 802.3af and 802.3at, which detail the minimum category cable, how power should be delivered, and limits in terms of watts. Many applications have been established in the commercial world (VoIP, surveillance cameras, access control devices, etc.), and are making headway into the industrial environment as well.

## Cabeling

Industrial Ethernet cable does have a similar color code to commercial Ethernet (ANSI/TIA 568-C.2). The tables below illustrate the typical color codes used for industrial Ethernet applications.

Pair assignment	Signal name	Two pair color code
Pair 1	TX+	White/Orange
Pair 1	TX-	Orange
Pair 2	RX+	White/Green
Pair 2	RX-	Green
Pair assignment	Signal name	Four pair color code
Pair 1	NA	White/Blue
Pair 1	NA	Blue
Pair 2	TX+	White/Orange
Pair 2	TX-	Orange
Pair 3	RX+	White/Green

Pair assignment	Signal name	Two pair color code
Pair 3	RX-	Green
Pair 4	NA	White/Brown
Pair 4	NA	Brown

## Ethernet Categories

Ethernet cables are referred to as category cables, because they are classified into specific categories of performance. The table below lists several common category cables and their associated frequency, speed, and number of pairs. Note, CAT 5e is available as either a 2-pair or 4-pair cable, but all 4-pairs are needed to achieve the 1000 Mbps speed; only 2-pairs are needed to achieve 100 Mbps.

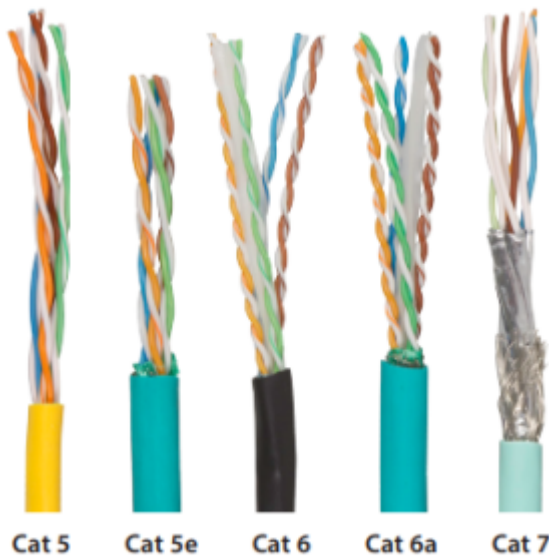

Category	Frequency	Speed	Pairs
Cat 5	100 MHz	100 Mbps	2-4
Cat 5e	100 MHz	1000 Mbps	2-4
Cat 6	250 MHz	1000 Mbps	4
Cat 6a	500 MHz	10 Gbps	4
Cat 7	600 MHz	10 Gbps	4

## Special IE protocolls

### Profinet

See: [Profinet](#)

### RSTP

**Rapid Spanning Tree Protocol** (*RSTP: IEEE 802.1w*) is a network protocol that is an advancement over **STP** - Spanning Tree Protocol (*STP: IEEE802.1D*) that promotes high availability and “loop-free” topology within Ethernet networks.

A primary advantage to RSTP networks is that they offer high availability when compared to traditional daisy chain topology. When a network failure does occur, devices are able to continue communicating across the network as data can be rerouted around the failure. Critical systems depend on a high level of resiliency to faults and hardware failures and RSTP provides a key improvement over traditional network architectures by minimizing downtime.

RSTP prevents network loops when using multiple switches by blocking redundant paths on a network. In essence, the protocol is a set of rules by which switches on the network determine the most efficient way to send broadcasts across the network by establishing a "root bridge" and blocking specific ports with the purpose of preventing network loops.

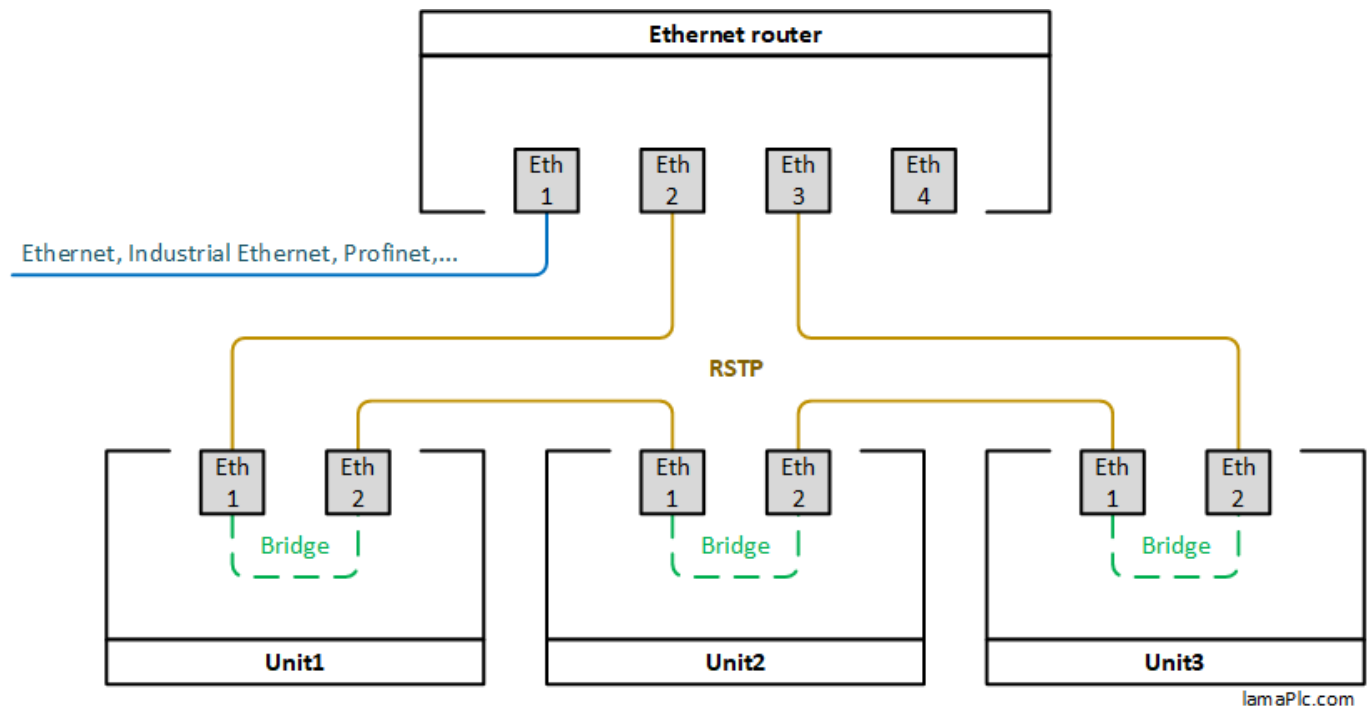

**RSTP**, along with its predecessor **STP**, was developed for the purpose of preventing detrimental loops within a network.

**RSTP** prevents network loops by blocking redundant ports. A blocked port will still receive data, but will not send that data out to other devices on the network. This ensures that switches will receive only a single copy of a packet. If any of the active paths fail, one of the blocked ports will be used. The port that is selected depends on the topology of the configuration.

RSTP is an improvement over **STP** (*Spanning Tree Protocol*) mainly due to its reduction in convergence time – that is, the time it takes all switches on a network to reach a state of convergence, or agreement, on the topology of the network. In STP, there is substantial convergence time whenever there is a topology change or failure in the network, which typically lasts for 40-50 seconds. RSTP reduces the convergence time significantly down to around 5-10 seconds.

Fortunately, many modern switches on the market automatically enable RSTP by default. Further, for networking environments with a mix of older and newer equipment, it is important to note that RSTP is backward compatible with the older STP standard.

- RSTP default port: 554
- STP default port: 128

# Sources

[Accuenergy: Rapid Spanning Tree Protocol \(RSTP\)](#)

## Industrial ethernet topics on lamaPLC

Page	Date	Tags
<ul style="list-style-type: none"><li>• <a href="#">lamaPLC Communication: AS-i</a></li></ul>	2026/04/23 21:51	<a href="#">bus</a> , <a href="#">communication</a> , <a href="#">as-i</a> , <a href="#">basic</a> , <a href="#">industrial ethernet</a> , <a href="#">devicenet</a> , <a href="#">interbus</a> , <a href="#">manchester-ii</a> , <a href="#">apm</a>
<ul style="list-style-type: none"><li>• <a href="#">lamaPLC Communication: EtherNet/IP</a></li></ul>	2026/04/23 21:51	<a href="#">communication</a> , <a href="#">ethernet</a> , <a href="#">bus</a> , <a href="#">ip</a> , <a href="#">cip</a> , <a href="#">ethernet ip</a> , <a href="#">udp</a> , <a href="#">industrial ethernet</a> , <a href="#">ie</a> , <a href="#">tcp</a> , <a href="#">unicast</a> , <a href="#">devicenet</a> , <a href="#">controlnet</a> , <a href="#">ieee 802.3</a>
<ul style="list-style-type: none"><li>• <a href="#">lamaPLC Communication: Sinec H1</a></li></ul>	2026/04/23 21:51	<a href="#">communication</a> , <a href="#">bus</a> , <a href="#">fieldbus</a> , <a href="#">sinec-h1</a> , <a href="#">s5</a> , <a href="#">s7</a> , <a href="#">simatic</a> , <a href="#">siemens</a> , <a href="#">industrial ethernet</a> , <a href="#">ie</a> , <a href="#">iec 8073</a>
<ul style="list-style-type: none"><li>• <a href="#">lamaPlc: Industrial Ethernet (IE) Basic</a></li></ul>	2026/04/23 21:51	<a href="#">communication</a> , <a href="#">bus</a> , <a href="#">ethernet</a> , <a href="#">industrial ethernet</a> , <a href="#">ie</a> , <a href="#">ethercat</a> , <a href="#">ethernet ip</a> , <a href="#">profinet</a> , <a href="#">powerlink</a> , <a href="#">sercos</a> , <a href="#">iii</a> , <a href="#">cc-link</a> , <a href="#">modbus tcp</a> , <a href="#">ieee</a> , <a href="#">rstp</a> , <a href="#">stp</a>

[communication](#), [bus](#), [Ethernet](#), [Industrial Ethernet](#), [IE](#), [EtherCAT](#), [EtherNet/IP](#), [PROFINET](#), [POWERLINK](#), [SERCOS](#), [III](#), [CC-Link](#), [Modbus TCP](#), [IEEE](#), [Profinet](#), [RSTP](#), [STP](#)

This page has been accessed for: Today: 1, Until now: 205

From: <https://lamaplc.de/> - **lamaPLC**

Permanent link: [https://lamaplc.de/doku.php?id=com:basic\\_ie](https://lamaplc.de/doku.php?id=com:basic_ie)

Last update: **2026/04/21 20:47**

