

NEMA types & drivers

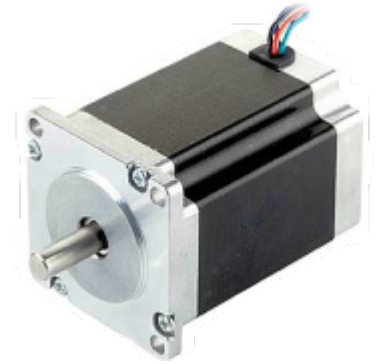

Internal Construction Types

Regardless of their physical size, NEMA steppers generally fall into three construction categories based on their rotor and stator design:

- **Hybrid (HB):** The most common type in industrial automation. It combines permanent magnets and a toothed rotor to provide high resolution (typically 1.8° steps) and high torque.
- **Permanent Magnet (PM):** Uses a non-toothed rotor with permanent magnets. These are generally lower cost but offer lower resolution and less torque than hybrid models.
- **Variable Reluctance (VR):** Uses a plain iron rotor without magnets. The rotor moves in response to the stator coils' magnetic field. These are less common today as they lack holding torque when the motor is unpowered.

Type	Rotor Design	Advantages	Disadvantages
Hybrid (HB)	Toothed, permanent magnet	High resolution (0.9°-1.8°), high torque	Most expensive type
Permanent Magnet (PM)	Non-toothed magnet	Low cost, decent torque	Low resolution (often 7.5°-15°)
Variable Reluctance (VR)	Toothed, iron (no magnet)	High speed, no magnetic "cogging"	No holding torque when unpowered

Electrical Configurations

NEMA motors are also distinguished by how their internal coils are wired, which determines what kind of driver you must use:

- **Bipolar:** Features two coils and four wires. These require more complex "H-bridge" drivers but offer superior torque performance.
- **Unipolar:** Usually has 5 or 6 wires with a center tap on each coil. They are easier to drive with simple circuits but typically produce less torque.

NEMA Frame Size Comparison

The NEMA number indicates the faceplate's approximate width and height in inches multiplied by 10 (e.g., NEMA 17 is 1.7" square).

NEMA Size	Faceplate Size (Approx.)	Typical Torque Range	Common Applications
NEMA 8	20 x 20 mm (0.8")	0.01 - 0.1 Nm	Miniature robotics, medical devices
NEMA 11	28 x 28 mm (1.1")	0.1 - 0.3 Nm	Medical printers, small CNC stages
NEMA 14	35 x 35 mm (1.4")	0.2 - 0.5 Nm	Desktop 3D printers, scanners
NEMA 17	42 x 42 mm (1.7")	0.3 - 1.2 Nm	3D printers, desktop CNCs, robotics
NEMA 23	56 x 56 mm (2.3")	1.2 - 4.5 Nm	Industrial CNC mills, laser cutters
NEMA 24	60 x 60 mm (2.4")	1.5 - 5.0 Nm	High-torque conveyors (non-standard NEMA)
NEMA 34	86 x 86 mm (3.4")	4.0 - 15 Nm	Heavy-duty CNC, industrial automation
NEMA 42	110 x 110 mm (4.2")	10 - 30 Nm	Large industrial machinery, presses

NEMA Stepper motor drivers

A stepper motor driver is an electronic device that serves as the interface between a control system (*such as a microcontroller*) and a stepper motor. Its primary function is to transform low-power digital signals into high-power electrical pulses that energize the motor's coils in a precise sequence to create incremental mechanical motion.



Core Functionalities

The driver manages several critical aspects of motor operation to ensure precision and prevent damage: **Power Amplification:** It converts low-voltage logic signals (typically 3.3V or 5V) from a controller into higher-voltage, higher-current (often 12V-48V or more) signals required to drive the motor.

- **Phase Sequencing:** The driver determines which motor windings to energize and in what order, thereby directly controlling the motor's direction (clockwise or counter-clockwise) and stepping.
- **Current Regulation:** To prevent the motor from overheating, drivers use techniques like current chopping (PWM) to maintain a constant average current even when the supply voltage is high.
- **Microstepping:** This functionality divides a single full step into smaller "*microsteps*" by proportionally energizing multiple coils. This leads to smoother motion, higher resolution, and reduced vibration.
- **Protection:** Most modern drivers include safety features such as overcurrent protection, thermal shutdown, and under-voltage lockout to safeguard the electronic components.

Microstepping

Microstepping is a method that increases stepper motor resolution by dividing each full step into smaller intermediate positions (for example, 1/4, 1/16, 1/64) using sinusoidal current control in the windings. It decreases vibration and noise, enhances smoothness, and reduces resonance, but may slightly lower torque.

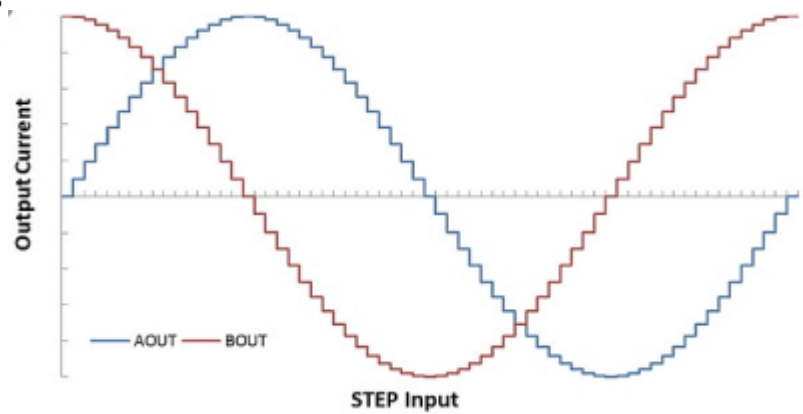

- **Operation:** Microstepping works by controlling the current in the motor coils to create intermediate magnetic positions between the physical poles.
- **Resolution & Smoothness:** Instead of, for example, 200 steps per revolution (per step), a 1/16th setting results in steps per revolution, allowing for much finer positioning.
- **Performance Improvements:** It significantly reduces noise and vibration, making it ideal for applications requiring quiet or smooth motion.
- **Trade-offs:** Higher microstepping levels can reduce torque and introduce potential accuracy limitations if not set correctly.
- **Configuration:** Motor drivers often use DIP switches (e.g., set to 1011 for specific microstepping ratios) to define the resolution.

Main Control Signals

Standard drivers typically use a simple “*Step and Direction*” interface:

- **STEP (or PULSE):** Each pulse received by this pin causes the motor to move one incremental step (or microstep). The frequency of these pulses determines the motor's speed.
- **DIR (DIRECTION):** The voltage level on this pin (high or low) tells the driver which way to rotate the motor.
- **ENABLE:** This signal allows the controller to turn the motor current on or off, which helps save power when the motor is idle.

Stepper driver wiring

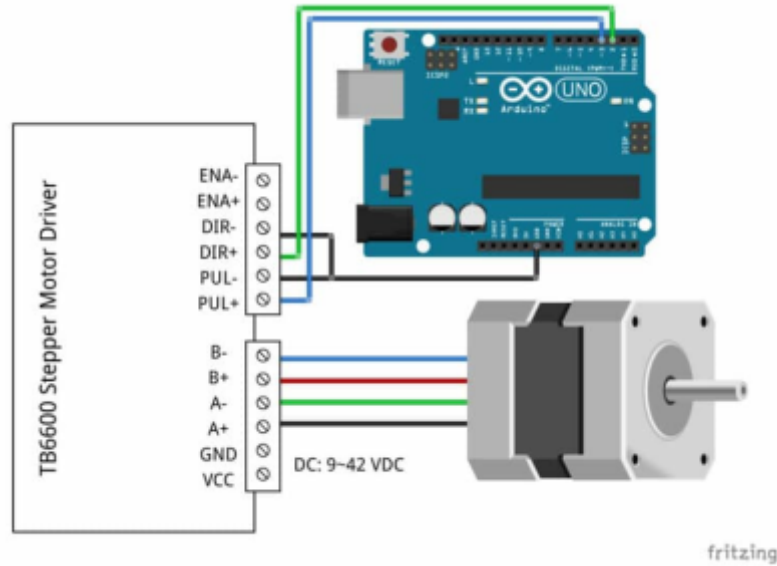

Common Driver Types

- **L/R (Constant Voltage) Drivers:** Older, simpler designs that use resistors to limit current. They are generally restricted to low-speed applications due to poor efficiency and high heat generation.
- **Chopper (Constant Current) Drivers:** The current industry standard. They use high-frequency switching to maintain precise current levels, allowing for higher torque at higher speeds.
- **Intelligent/Programmable Drivers:** Integrated units that can be configured via software (USB, RS485, etc.). They can often execute complex motion profiles without an external pulse generator.

Compare some common stepper motor drivers

Stepper motor drivers like the TB6600, DM556, and DM860 vary primarily in their power handling capabilities and control technology (analog vs. digital). While the TB6600 is a cost-effective analog driver, the DM series uses digital signal processing (DSP) to provide smoother motion and quieter operation.

Feature	TB6600	DM542	DM556	DM860	DM860H
Technology	Analog (Chip-based)	Digital (DSP)	Digital (DSP)	Digital (DSP)	Digital (DSP)
Input Voltage	9V - 42V DC	20V - 50V DC	20V - 50V DC	24V - 80V DC	24V - 110V DC 18V - 80V AC
Peak Current	4.0A	4.2A	5.6A	7.8A	7.2A - 8.4A
Max Microstep	6400 steps/rev (1/32)	25600 steps/rev (1/128)	25600 - 102400 steps/rev	51200 steps/rev	51200 steps/rev
Pulse Frequency	Up to 20kHz	Up to 200kHz	Up to 200kHz	Up to 200kHz	Up to 200kHz

Feature	TB6600	DM542	DM556	DM860	DM860H
Ideal Motor	NEMA 17, 23	NEMA 17, 23, 24	NEMA 23, 24, 34	NEMA 34	NEMA 34, 42





Key Performance Differences

- **TB6600:** This is the budget-friendly choice for hobbyist projects like small 3D printers or light-duty CNCs. It is known to produce more audible motor noise (hissing) and rougher steps compared to digital drivers.
- **DM542 & DM556:** These are the “sweet spot” for performance and reliability. They feature anti-resonance algorithms that minimize vibration and mid-range instability, making them much quieter than the TB6600.
- **DM860 & DM860H:** These are heavy-duty industrial drivers designed for large motors, such as NEMA 34. The “H” in DM860H typically indicates a high-voltage version that can often accept AC power directly, and features improved thermal management.

NEMA Mini Stepper motor drivers

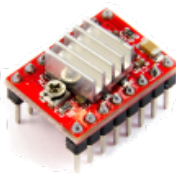
Compare some mini stepper drivers

To compare these stepper motor drivers, they can be broadly categorized into “classic” drivers (A4988, DRV8825) known for their reliability and simplicity, and “silent” Trinamic drivers (TMC series), which feature advanced technologies like StealthChop for near-silent operation.

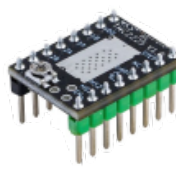
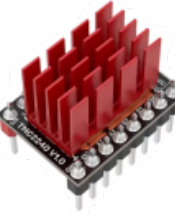
Feature	A4988	DRV8825	TMC2208	TMC2209	TMC2225	TMC2240
						
Max Current (RMS/Peak)	1.0A / 2.0A	1.5A / 2.5A	1.2A / 2.0A	2.0A / 2.8A	1.4A / 2.0A	3.0A / 4.4A
Voltage Range	8V - 35V	8.2V - 45V	4.75V - 36V	4.75V - 28V	4.75V - 36V	4.5V - 60V
Max Microsteps	1/16	1/32	1/256 (int.)	1/256 (int.)	1/256 (int.)	1/256 (int.)
Silent Mode	No	No	Yes (StealthChop2)	Yes (StealthChop2)	Yes (StealthChop2)	Yes (StealthChop2)
Interface	STEP/DIR	STEP/DIR	STEP/DIR, UART	STEP/DIR, UART	STEP/DIR, UART	STEP/DIR, SPI/UART
Special Features	Simple, cheap	High voltage	Ultra-silent	Sensorless homing	Upgraded 2208 package	High performance

Key Differences & Use Cases

- **Classic Drivers (A4988 & DRV8825):** These are the most cost-effective options for basic projects where noise isn't a primary concern. The DRV8825 is preferred for higher voltage setups up to 45V.
- **The Silent Standard (TMC2208 & TMC2209):** These drivers are the go-to for quiet 3D printing. The TMC2209 is a notable upgrade over the 2208, offering higher current capacity and StallGuard4 for sensorless homing.
- **TMC2225:** Essentially a TMC2208 in a different package (HTSSOP), often providing better heat

dissipation at a lower price.

- **High Performance (TMC2240):** The latest in the lineup, TMC2240 performs well in demanding industrial environments, with a wide voltage range (up to 60V) and the highest current capacity among the options.

NEMA topics on lamaPLC

Page	Date	Tags
• NEMA types & drivers	2026/04/23 21:51	a4988 , drv8825 , tmc2208 , tmc2209 , tmc2225 , tmc2240 , tb6600 , dm556 , dm542 , dm860 , dm860h , nema , stepper , motor , nema 8 , nema 11 , nema 14 , nema 17 , nema 23 , nema 24 , nema 34 , nema 42

[A4988](#), [DRV8825](#), [TMC2208](#), [TMC2209](#), [TMC2225](#), [TMC2240](#), [TB6600](#), [DM556](#), [DM542](#), [DM860](#), [DM860H](#), [nema](#), [stepper](#), [motor](#), [NEMA 8](#), [NEMA 11](#), [NEMA 14](#), [NEMA 17](#), [NEMA 23](#), [NEMA 24](#), [NEMA 34](#), [NEMA 42](#)

This page has been accessed for: Today: 1, Until now: 146

From:
<http://lamaplc.com/> - **lamaPLC**

Permanent link:
<http://lamaplc.com/doku.php?id=actor:nema>

Last update: **2026/04/21 20:48**

